

BOM LIST			
ITEM	PART NAME	Q'ty	NOTES
1	PLASTIC HOOD	2	SEE P/N
2	2.1 LONG BOLT	2	#4-40
	2.2 SHORT BOLT	2	#4-40
3	NUT	2	M3
4	LONG SCREW	2	M3
5	SMALL WASHER	2	
6	SHORT SCREW	2	M3
7	METAL WASHER	2	M3

REV.	DESCRIPTION	DRAWN	CHECKED	APPROVED
A	NEW RELEASE	LJH 08/13/05'	~	LJC 08/13/05'
C	整理英制短螺丝尺寸	YCH 07/18/08'	~	LJC 07/18/08'
D	增加“全包装”类型	YCH 05/20/10'	~	LJC 05/20/10'
E	改M3*12的螺钉为M3*10	YCH 08/30/10'	~	LJC 08/30/10'
F	ADD P/N CODE	LJC 12/24/13'	~	LJC 12/24/13'
H	ADD LOGO	JLZ 12/17/14'	~	

NOTES:

1. Hardwares are all Nickel plated.
2. PART NUMBER CODE:

DS1045 - 09 X X X X X - X

Hood Materials (F)

- A: ABS
- B: Similar ABS

Washer type
1: Metal

Bolt type
L: Long
S: Short

Packing type
1: Mix packing
2: Separation packing
Q: Full packing

Cover Material
P: Plastic(ABS)
Cover Color

- A: Gray
 - B: Black
 - V: Ivory
- Position
09: 9pin

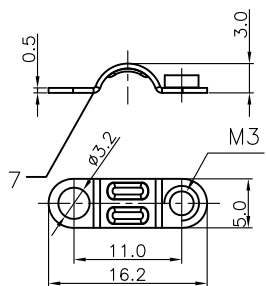
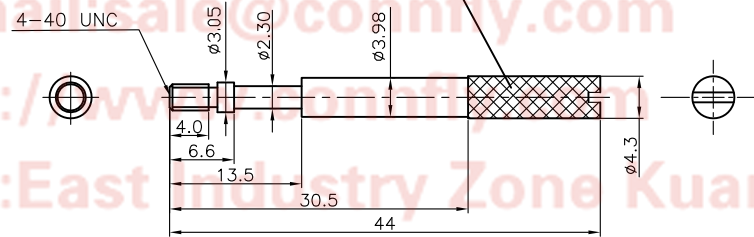
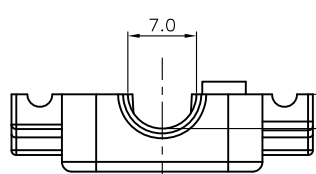
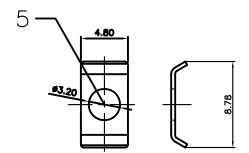
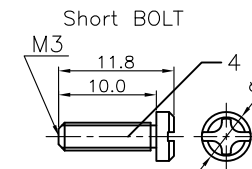
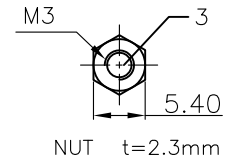
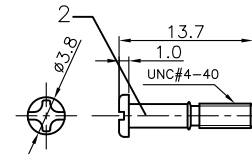
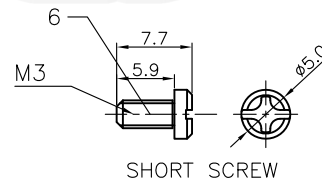
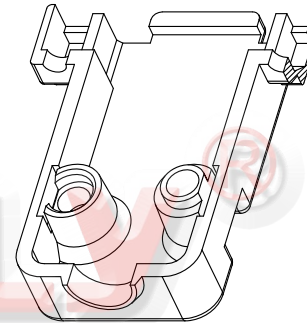
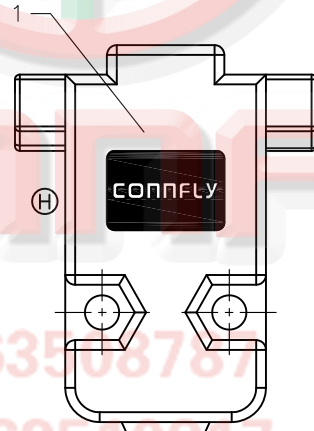
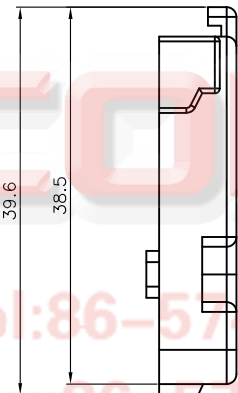
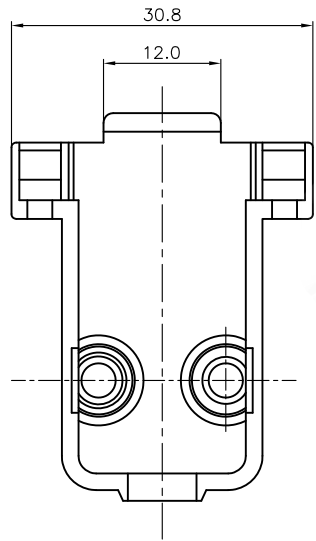
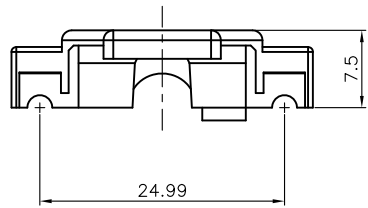

Long BOLT

GENERAL TOLERANCE		ANGLE TOLERANCE	
X.	±0.60	X.	±5°
.X	±0.38	.X	±3°
.XX	±0.25	.XX	±2°

PROJECTION	TITLE	D-SUB Plastic Hood 180° 9 Positions	
UNITS	mm		
SHEET SIZE	A4	SERIES	DS1045 SERIES

DRAWING TYPE	COSTOMER		
SCALE	1:1	SHEET	1 OF 1
DRAWING NO.	C-DS1045-09XXXXX-X-H		

 晨翔电子有限公司
CONNFLY ELECTRONIC CO., LTD

Tel:86-574-63508787
Fax:86-574-63510817
E-mail:sale@connfly.com
http://www.connfly.com
Add:East Industry Zone KuangYan
Town Cixi Ningbo China
P.C:315333